

## Design, Construction and Testing of a Chalk Moulding Machine

I. G. Davou Chomo, L. I. Pam and Z. S. Johnson\*

Mechanical Engineering Department, Plateau State Polytechnic, Barkin Ladi, Plateau State, Nigeria.  
Corresponding Author E-mail: [zsjohnson2006@gmail.com](mailto:zsjohnson2006@gmail.com)

Received 2 September 2018; Accepted 20 September, 2018

The ever increasing number of schools in Nigeria and other developing countries enlarges the demand and consumption of chalk. To meet this demand, it is imperative to align the demand with production. The aim of this work is to design, construct and test a chalk moulding machine with high level of local content and competitive produce. The constructed moulding machine was able

to produce seventy-three packets of chalk, each packet containing eighty sticks of chalk, with an efficiency of seventy-six percent. The chalk produced writes smoothly and is easily erased.

**Keywords:** Diagenesis, Chert, Flint, Calcite, Calcium Carbonate

### INTRODUCTION

Chalk is a major instructional material in developing countries. In Nigeria both public and private schools consume large quantity of white and coloured chalk which makes the chalk moulding machine to be in high demand. It is the object of this design to produce a chalk moulding machine that satisfies the ever increasing demand for chalk with high level of local content at competitive cost. This will boost the morale of investors. Chalk production is lucrative in Nigeria because there is an ever increasing number of public and private schools nationwide. To meet up this demand, individuals and corporate organizations have delved into school chalk production and supply with a bid to balance the demand. This has not been successful, as schools keep springing up on daily basis while the demand keeps skyrocketing. This has created a very big investment opportunity especially for individuals who intend to go into small scale chalk production business (Ribina et al., 2014).

#### Chalk sticks

Chalk is porous, soft when touched and white in appearance. Technically it is a sedimentary rock, a form of limestone composed of calcite. Calcite is calcium

carbonate ( $\text{CaCO}_3$ ) with minor amounts of silt and clay. It is normally formed under water, commonly on the sea bed, from the gradual accumulation of minute calcite plates, then consolidated and compressed during diagenesis into the form commonly seen today. During diagenesis silica accumulates to form chert or flint nodules within the carbonate. Chalk can also refer to another compounds including magnesium silicate and calcium sulphate (Chalk, 2014; Blount, 1990; Huxley, 1868) Chalk sticks are processed and produced for use with blackboards which are available in various colours. Coloured chalk is often made not from chalk rock but from calcium sulphate in its dehydrate form, gypsum (Chalk, 2014). The traditional use of chalk has in some cases been replaced by other substances, although the word "chalk" is still applied to the usual replacements. Blackboard chalk can be used on rough surfaces, as it readily crumbles leaving particles that stick loosely to these surfaces (Chalk, 2014; Blount, 1990).

#### Chalkboard

The chalkboard or blackboard is a reusable writing surface on which text or drawings are made with sticks of



**Figure 1.** A modern green chalk. Source: (Nkwocha, 1998).

chalk. Blackboards were originally made of smooth, thin sheets of black or dark grey slate stone (Figure 1). Modern versions are often green because the colour is considered easier on the eyes (Nkwocha, 1998). A blackboard can simply be a piece of board painted with matte dark paint (usually black or dark green). A more modern variation consists of a coiled sheet of plastic drawn across two parallel rollers, which can be scrolled to create additional writing space while saving what has been written. The highest grade blackboards are made of rougher version porcelain enamelled steel (Chalk, 2014). The first classroom uses of large blackboards are difficult to date, but they were used for music education and composition in Europe as far back as the sixteenth century (Owens, 1998). The blackboard was introduced into the US education system from Europe in 1801. This occurred at West Point, where George Baron, an English mathematician, used chalk and blackboard in a lecture (Ambrose, 1999). James Pillans has been credited with the invention of coloured chalk; he made a recipe with ground chalk, dyes and porridge (Swinnerton, 2013). Lecture theatres may contain a number of blackboards in a grid arrangement, where boards can be moved into reach for writing and then moved out of reach, allowing a large amount of material to be shown simultaneously (Nkwocha, 1998). Chalk marks can be easily wiped off with a damp cloth, a sponge or a special blackboard eraser consisting of a block of wood covered by a felt pad. However, chalk marks made on some types of wet blackboard can be difficult to remove.

As compared to whiteboards, blackboards according to Chalk, (2014) have a variety of advantages which includes:

- (a) Chalk requires no special care; whiteboard markers must be capped or else they dry out.
- (b) Chalk is cheaper than whiteboard markers for a comparable amount of writing.
- (c) It is easier to draw lines of different weights and thicknesses with chalk than with whiteboard markers.
- (d) Chalk has a mild smell, whereas whiteboard markers often have a pungent odour.
- (e) Chalk writing often provides better contrast than whiteboard markers.
- (f) Chalk can be easily erased; writing on a whiteboard left for a prolonged period may require a solvent to remove.
- (g) Chalk can be easily removed from most clothing; whiteboard markers often permanently stain fabric.

The disadvantages of chalkboard according to chalk (2014) include firstly, that chalk produces dust and the amount of dust depends on the quality of the chalk. Secondly, some people are not comfortable with dust while some may be allergic to it. According to the American Academy of Allergy, Asthma and Immunology (AAAAI), there are links between chalk dust and allergy and asthma problems (WebMD, 2000). The dust also precludes the use of chalk in areas shared with dust-sensitive equipment such as computers. Thirdly, the scratching of fingernails on a blackboard, as well as other pointed, especially metal objects against blackboards produces a sound that is well known for being extremely irritating to most people.

Many are averse also to merely the sight or thought of this sort of contact.

## CHALK PRODUCTION

Chalk is manufactured in one of two methods. In the first method the chalk is moulded, while in second chalk is pressed and extruded, like toothpaste from a tube. Extruded chalk, whether white or specifically coloured, is most commonly used on chalkboards in school, as it tends to be dense and "dustless".

### Extruded chalk production

To manufacture extruded chalk several white powders which look like flour are first stirred by machine. The most important of these is calcium carbonate and water-washed clay. If the chalk is to be coloured, the particular colour is also added in the form of dry, finely ground pigments. When the mixture is well mixed, it is transferred to another large machine where a liquid "binder" is poured in to hold the dry particles together (Binney and Smith Inc, 2002). After the powders and their binder have swished around for a certain length of time, the chalk forms a kind of dough which looks like many small balls about the size of marbles. These little dough balls are then machine-pressed into a large, long shape, just like a solid cylinder. This shape is called a cartridge. As a result of this pressing, air is forced out of the dough, and the moist particles in the dough are very closely bound to one another causing the chalk to be heavy and smooth textured (Binney and Smith Inc, 2002). The cartridge, which is still damp and pliable, is then inserted into another machine called an extrusion press, where it is forced through a small tube. As the long rope of wet chalk comes out, an automatic slicer cuts it into many pieces. These pieces roll down to a tray, and are ready to be cut again into regular size sticks of chalk. Since the pieces are still quite moist, they must be dried in large ovens, called kilns, before they become hard enough to be packed (Binney and Smith Inc, 2002). Extruded chalk is described as "dustless" but however all chalk, being dry, is naturally dusty. In the case of extruded chalk, however, the dust particles fall straight down instead of flying through the air to make you sneeze. In other words, the dust in "dustless" chalk is chemically controlled (Binney and Smith Inc, 2002).

### Moulded Chalk production

The moulded chalk is softer than extruded chalk, and is definitely not dustless. Dry pigment and water are first mixed in preparation for the addition of plaster of Paris. Because plaster begins to set quickly, this process must be carefully timed and supervised. Before the mixture gets too thick, it is poured into a mould on the moulding machine. The mould has many holes with the exact size and shape of the finished pieces of chalk. Excess chalk is scraped off the tops of the moulds with a wooden paddle,

and after setting for five to eight minutes, depending on the particular colour being manufactured, the sticks of chalk are popped out onto a wooden tray which is then stacked in a large drying rack. Like the extruded chalks, these are kiln-dried and packaged (Binney and Smith Inc, 2002). Both moulded and extruded chalks are manufactured in a variety of colours and shapes. There are round sticks, long square ones, and even hemispheres, and their uses are varied. Chalks made for school and home are different from those needed in an art studio or factory (Binney and Smith Inc, 2002). There are different types of moulding machines in existence among them are plastic chalk moulds, rubber, and metallic alloyed mould. The alloyed moulds cut across copper, brass and aluminium. The present mould, designed and fabricated out of wooden block with galvanised tubes offers a cheaper solution while offering cost savings in materials. It gives a lighter weight in the final construction without compromising the main parameters of the size of the chalk length and tensile strength of the final product. Existing metallic moulds made of stainless steel, copper tubing or brass add weight to the final block, and adds cost to the average small scale producer.

## MATERIALS SELECTION, FABRICATION AND TESTING

### Materials Selection

Several requirements were put into consideration during materials selection which was used in manufacturing the machine. The following are the basic requirements which were considered: Rigidity, material availability, corrosion resistance, flexibility of parts, cost of materials, and feasibility after construction. Table 1 outlines the major components and the material used on the construction. The reason why the materials are selected is also provided while (Figure 2) shows the complete assembly after construction.

### Functions of each part of the mould

The mould is made up of wood where the mixed material for the production of chalk is poured unto. The mould has square cross sectional measuring 20 cm x 20 cm and a depth 10 cm. The mould creates a means for the chalk slurry to be poured into tubes before ejection takes place. Figure 3 is an explosion of the moulding machine. The various part of the mould is shown in the (Figure 3). The base plate carries the pistons used for ejection. The plate measures 250 mm x 4 mm and is clamped to the mould so that the mould serves as a guide for the pistons on the base plate to ensure that all the pistons on the base plate

**Table 1.** Materials Selected and reasons for selection.

Component	Material	Reason for use
Shaft	Mild steel	Availability, high strength, wear resistance
Rack	Mild steel	Availability, high strength, wear resistance
Pinion	Mild steel	Availability, high strength, wear resistance
Base plate	Mild steel	Availability, high strength, wear resistance
Frame	Mild steel	Availability, high strength, wear resistance
Tubes	Galvanized plate sheet	Availability, high strength, wear resistance
Mould	Wood (obeche)	Availability, cost effective
Piston cap	Aluminium	Low weight, ease of manipulation
Piston rod	Mild steel	Availability, high strength, wear resistance
Bolt and nut	Mild steel	Standard
Bearing	High carbon steel	Standard

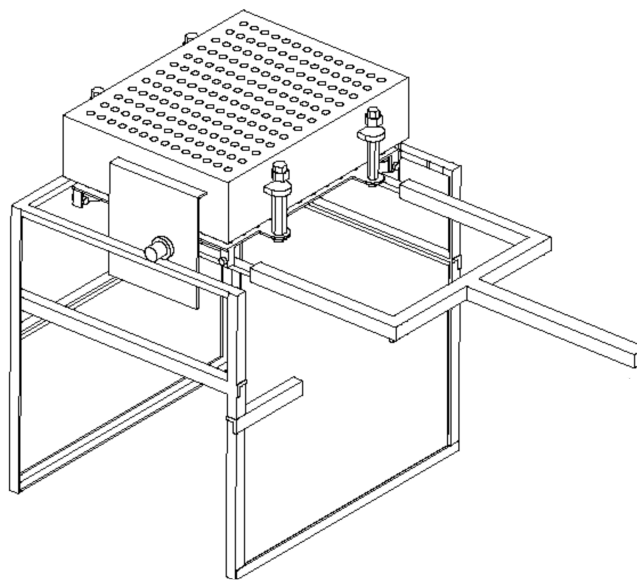

**Figure 2.** Chalk Moulding Machine.

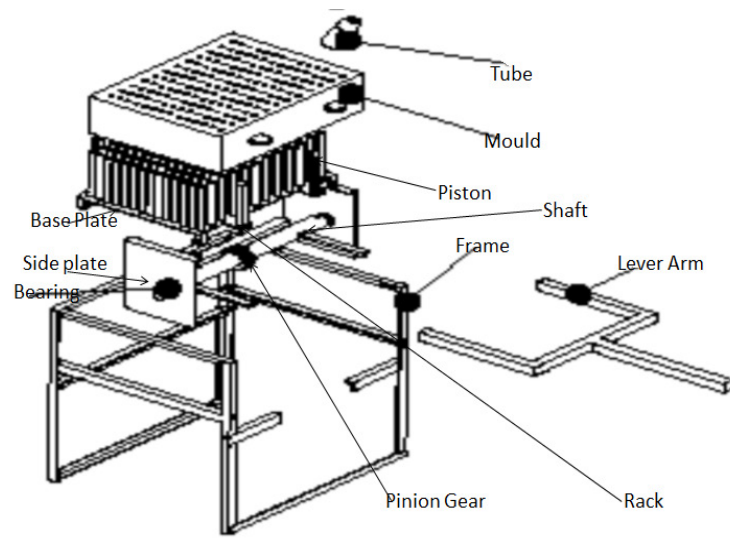

**Figure 3.** Exploded View of Chalk Moulding Machine.

**Table 2.** Performance of the machine recorded during the test.

Test no.	Unbroken sticks	Broken Sticks
1	130	62
2	150	42
3	157	35
Average	146	46

aligns with the holes on the mould. The function of the base plate is to hold and keep all the pistons rods in vertical position inside the mould tubes. The piston rod pushes the chalk out of the piston when it sets. It has a diameter of 8 mm and length of 110 mm. The dimension of the tubes is gotten from the standard size of chalk since the chalk is usually tapered the galvanized material is cut and folded into a frustum. The pinion is a standard component which is readily available and selected based on design. When the pinion rotates on the rack, the pistons lift up thereby ejecting the chalk out of the mould. The frame is designed to carry load without failure. It is made from angle iron in a square and supported on four stands. The shaft is placed horizontally passing through the pinion which is connected to the rack. The function of the lever arm is to create motion along the rack and pinion unit to convert rotary motion to linear motion. The lever arm is made from round pipes and formed into a u-shape. It has an arm on one side which enables the operator to lift the piston.

## RESULTS AND DISCUSSION

Using a paint brush the tubes and moving parts are first cleaned with a mixture of Kerosene and groundnut oil as the lubricant in the ratio 1:1 to remove all dust and make the machine free for ejection. The mixture of the calcium carbonate, gypsum, catalyst and water are blended, measured in the right ratio and volume and then mixed with water to forms a paste. The mould is arranged properly and the paste is then poured into the cavities of the mould and the mixture is allowed to set for about 15 to 20 min after which the mould is turned by 180° (upside down). The collecting rack is placed under the block; the lever is pushed upward thereby converting the rotary motion of the pinion into a linear motion of the rack. The rack pushed the base carrying the pistons and the pistons eject the chalk to the collecting rack. The chalk is sundried naturally or artificially in an oven with a temperature between 75-85°C. Finally, the dried chalk is packaged in branded carton packs. The dried chalk is arranged inside a 140 mm x 80 mm x 60 mm packet which can take up to 80 sticks of chalk. Twelve of these packets are then packed into printed cartons for storage and sales (Table 2).

$$\text{Efficiency} = \frac{146}{146+46} \times 100 = \frac{146}{192} \times 100 = 76\%$$

Average number of broken sticks for one production run= 146

Average time in an 8 hours working day= 12 minutes

Number of runs in an 8 hours working day=  $\frac{8 \times 60}{12} = 40$

Quantity of chalk sticks produced per day= 40x14= 5840 sticks of chalk

Number of sticks in one packet= 80

Number of chalk manufactured in a day=  $\frac{\text{Total sticks produced per day}}{\text{Number of chalk per packet}} = \frac{5840}{80} = 73$  packets

## Conclusion

In conclusion, the chalk moulding machine has been designed, fabricated, and tested using local materials. If properly utilized, the machine could produce 5840 sticks of chalk in a day which translates to 73 packets per day. The chalk is easily erased, writes smoothly and does not scratch the board.

## REFERENCES

- Ambrose SE (1999). Duty, Honor, Country: A History of West Point. JHU Press. p. 19. Retrieved 14 February 2013 from [http://books.google.com/books?id=SCwr5A\\_hbkC&pg=PA19](http://books.google.com/books?id=SCwr5A_hbkC&pg=PA19)
- Binney and smith Inc. (2002). Retrieved September 6, 2017 from [http://www.trainweb.org/oldtimetrains/CPR/general/chalk\\_making.htm](http://www.trainweb.org/oldtimetrains/CPR/general/chalk_making.htm)
- Blount B (1990). Chemistry for Engineers and Manufacturers: Chemistry of manufacturing processes. University of Wisconsin - Madison.
- Chalk (2014). Retrieved December 7, 2014 from <http://en.wikipedia.org/wiki/chalk>
- Huxley TH (1868). On a piece of chalk. Macmillan's magazine. Retrieved from <http://aleph0.clarku.edu/hexley/CE/8/Chalk.html>
- Nkwocha C (1998). How to make school chalk at home and sell for profit. Retrieved September 6, 2017 from [www.homebusinessmanual.com/2012/07/how-to-make-school-chalk](http://www.homebusinessmanual.com/2012/07/how-to-make-school-chalk)
- Owens JA (1998). Composers at Work: The Craft of Musical Composition, 1450-1600. Oxford University Press, 1998.
- Ribina JN, Oada SM, Fom MD (2014). Design construction and testing of a chalk moulding machine. An unpublished HND Project report. Plateau state polytechnic, Barkin Ladi.
- Swinnerton J (2005). The history of Britain companion. Anova Books. p. 128. Retrieved 14 February 2013. From <http://books.google.com/books>.

WebMD (2000). Reading, writing, and Wheezing?Not Necessary.  
Athma Health Centre. Retrieved September 19, 2000 from  
<http://www.webmd.com/athma/news/20000919/>.