

Short Communication paper

Electromechanical Recycler: A Panacea for Epileptic Power Supply in Nigeria

Engr. Mmom, Chidaka Wisdom

Department of Electrical and Electronic Engineering, Port Harcourt Polytechnic Rumuola Port Harcourt, Rivers State, Nigeria.

Author E-mail: wischix4sure@yahoo.co.uk, wisdom.mmom@yahoo.com

Received 8 April 2023; Accepted 26 April 2023; Published 2 May 2023

ABSTRACT: This paper presents the concept of energy recycling as a solution to the epileptic nature of the power supply in Nigeria. The design uses dc/ac motor cascaded to an ac alternator through a pulley system. A dc supply is used to excite the dc motor, this in-turn, links the ac alternator through a pulley-belt system, and the output voltage generated by this system gives 240 volts which is used to run ac loads at homes, offices and industries. This system is efficient and reliable since the power generated can be recycled to keep the system running.

Keywords: DC motor, AC motor, Alternator, Rectifier, Capacitor

Citation: Mmom, C. W. (2023). Electromechanical Recycler: A Panacea for Epileptic Power Supply in Nigeria. Direct Res. J. Eng. Inform. Tech. Vol. 11 (5), Pp.57-59. <https://doi.org/10.26765/DRJEIT660173594>

INTRODUCTION

Constant power supply is a necessity to life and to the development of any country. The epileptic power supply in Nigeria is a major cause of under development of businesses. With constant power supply, people are empowered from the domestic level and the cottage industries, through small and medium scale industries to employment in large scale industries. Energy is a foundation stone of the modern industrial economy. Energy provides an essential ingredient for almost all human activities. It provides services for cooking and space/water heating, lighting, industry, food production and storage, education, mineral extraction, industrial production and transportation. Modern energy services are a powerful engine of economic and social development, and no country has managed to develop much beyond a subsistence economy without ensuring at least minimum access to energy services for a broad section of its population. Throughout the world, the energy resources available and their ability to pay largely determine the way in which people live their lives.

The epileptic nature of our power in Nigeria has resulted in loss of lives; this is because people resorted in the use

of generators that emit carbon monoxide which is poisonous to the body. We have had cases where families lost their lives as a result of the carbon monoxide (CO) emitted from generator exhaust. If there had been a constant public power, no one would think of running a private generating set. The use of these generators, result in noise and air pollution which also lead to global warming. People also spend much money on fuel daily thereby channeling the resources meant for food to power supply. It is on this premise that this paper becomes necessary as a remedy to the epileptic power supply in Nigeria.

Literature review

Paramahansa, (2014), created the first working over-unity reactionless generator. In his design, he had a conductor about a foot long which is allowed to rotate at the centre and connected at each end with a small gauge wire. A magnetic circuit is placed under the conductor, and so when a current was allowed to flow through the

conductor, it rotated due to the torque induced on the conductor according to Flemings Left Hand Rule. David, (2012) produced his own self running generator using different things like electrical hand-drill and bicycle. In his hand-drill experiment, the output of his design is connected to an inverter to generate alternating current voltage, although, the power generated was small.

Lester (1928) produced a fuel-less generator, he develop power by cutting the Earth's magnetic field as a normal generator does. He explained that he was tapping the Earth's magnetic field and rotation as its energy

source, his device was a self-running oscillator and was not actually a motor but a generator which develop electricity that could power another motor but did not produce any usable motion itself.

Otunlana et al. (2015) constructed a fuel-less generator using a 12V dc motor coupled to 1kVA alternator. In their design, the alternator and dc motor were coupled using two flat plates of 0.7mm thickness using bolts.

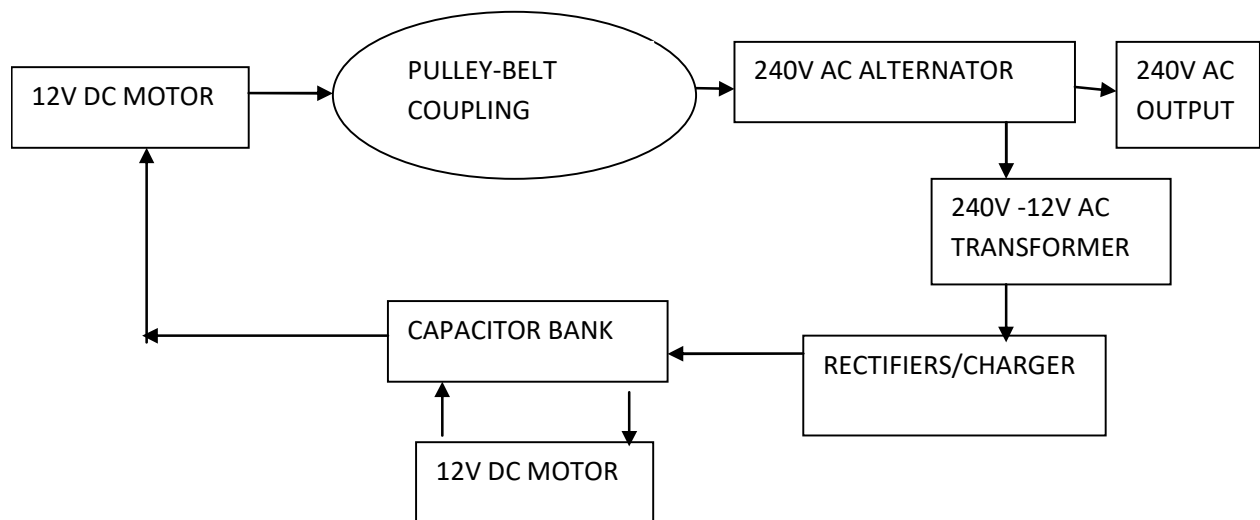

Figure 1: DC-AC Block Diagram.

DESIGN METHODOLOGY

In order to achieve the objective of the paper, the design methodology is broken down into different block diagrams as seen in (Figure 1).

A dc motor is any class of rotary electrical machine that converts direct current electrical energy into mechanical energy. An alternator is an electrical generator that converts mechanical energy to electrical energy in the form of alternating current.

The 12V battery through the capacitor bank supplies the required dc of the motor, when this happens, the motor rotates, and with the help of a pulley-belt coupling system, the alternator rotates, the rotation of this alternator produces an output voltage of 240V AC which is fed to the home appliances.

The same 240V output is channeled to a rectifier/charging system after being stepped-down to 12V using a step-down transformer. The output of the rectifier circuit goes to the battery through the capacitor bank. It is important to state that these capacitors charge and discharge as required.

This is a continuous power generation because the system cannot go off since it has a feedback from its output to charge the battery. There is always a constant dc supply to the motor. It is important to say that this system is self-sustaining; the battery can be used to start the system and thereafter removed. In this case, the battery starts the system, charges the capacitor for 3 minutes, as the dc motor rotates; alternating current is produced by the alternator which in-turn feeds back to the motor through the capacitor. Thus even when the battery has been removed, the system keeps running.

This process can also be implemented using ac motor as shown in (Figure 2); this does not require a battery nor a rectifier/ charging system. The ac motor is excited using an ac source for 3 minutes, a feedback from the alternator is fed to the ac motor, thus, as the motor rotates, voltage is produced at the alternator output which is also sent back to the motor. Thus, even when the ac source has been removed, the system still can be self-sustaining. It is important to say that in the absence of an external ac source, rotation can be done manually (rotate with hands), without any load on the alternator.

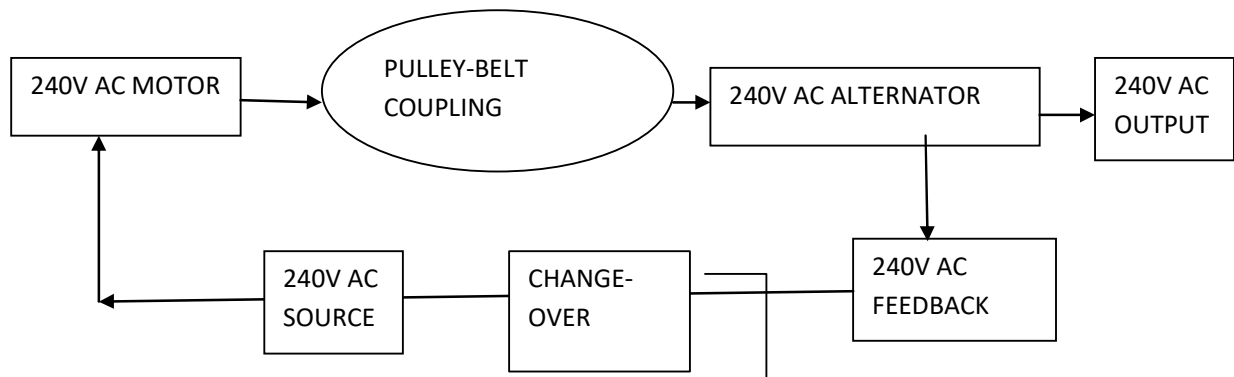

Figure 2: AC motor-AC Alternator.



Figure 3: System Coupling.

The alternator can be loaded only when the system has gained momentum.

RESULTS AND DISCUSSION

The result obtained after a systematic design methodology has been carried out shows that a sustainable power supply that needs no fuel, engine oil nor gas has been achieved. The overall assembly is shown in (Figure 3). The power generated here is a function of the size of motors and alternators used, it is self sustaining and pollution free, and it produces the same power like that of a public supply, an inverter or a normal mechanical generator.

Conclusion

The importance of electricity cannot be over emphasized; it is the key component to modern technology. Without electricity in the hospital for example, life would be a misery, without electricity, our mobile phone would not work. At homes and offices, constant power supply is

needed to make life comfortable; it keeps our lives in order, electricity runs everything in our everyday lives. Thus, in order to reduce the high cost of living, there is a need for a constant power supply in our homes, offices and business areas. Finally, if we key into this technology, we will not only reduce the cost of living in Nigeria, but also stop air pollution which has depleted the ozone layer thereby causing global warming.

REFERENCES

- David, D. (2012) homemade electric generator. Dubai: Survival Mastery
 Lester, H. (1928) Hendershot Fuel less Generator. Pennsylvania: cornel University press.
 Otulana, J.O., Akinwunmi, A.A., Awoyemi, J.A., Adeleke, M.B., and Efunbote, O.M.I. (2015). construction of fuel less generator. Nigeria: Abiola polytechnic.
 Paramahansa, T. (2014). Free Energy Perpetual Motion Generator. India: Toby Grotz.